

# Fine Pole Magnetic Plate

**VERTEX**  
MAGNETIC FORCE 21KGF  
700 GAUSS

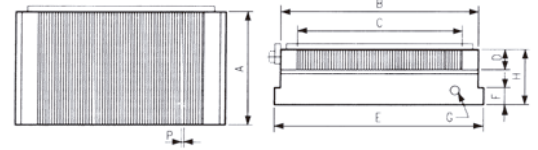
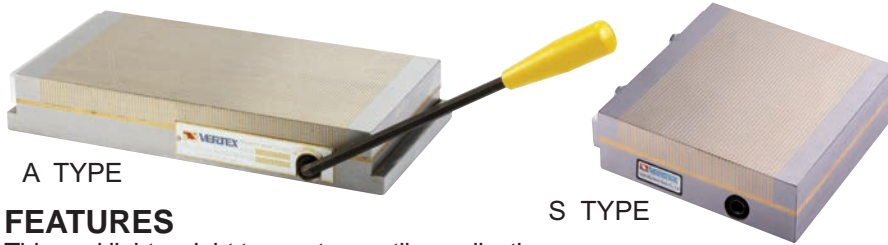

## FEATURES

Thin and light weight to meet versatile applications.

Fine-pitched magnetic poles on this micropitch model. Make it ideally suitable for small and thin works.

Hexagonal wrench key is used for the magnetic ON/OFF change over handle. It is inserted through the side, easily removed and operates lightly.

The chuck surface has a wider effective magnetic area than other chuck of similar type.

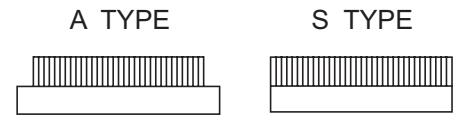

Unit:mm

ORDER NO.	SIZE	CHUCKING SIZE				POLE PITCH P	CHUCK MOUNTING FACE			HEIGHT H	WEIGHT KGS	CODE NO.	
		A	B	C	D		A	E	F				
VRTW-1018A	100X175	100	175	146	18	2.5 (1+1.5)	100	195	15	50	7.7	2015-130	
VRTW-1515A	150X150	150	150	116			150	170	15		9.8	2015-131	
VRTW-1530A	150X300	150	300	256			150	320	15		18.7	2015-132	
VRTW-1535A	150X350	150	350	306			150	370	15		21.4	2015-133	
VRTW-1540A	150x400	150	400	356			150	420	15		23.7	2015-134	
VRTW-1545A	150X450	150	450	406			150	470	15		27.4	2015-135	
VRTW-2040A	200X400	200	400	356			200	420	15		32.5	2015-137	
VRTW-2045A	200X450	200	450	406			200	470	15		36.4	2015-138	
VRTW-1224A	300X600	306	600	556			300	620	15		73	2015-138A	
VRTW-1018S	100X175	100	175	146			100	175	-		8	2015-139	
VRTW-1515S	150X150	150	150	121			150	150	-		9	2015-140	
VRTW-1530S	150X300	150	300	256			150	300	-		20	2015-141	
VRTW-1325S	125X250	125	250	206			20	125	250		15	13.1	2015-142

# Round Type Magnetic Plate

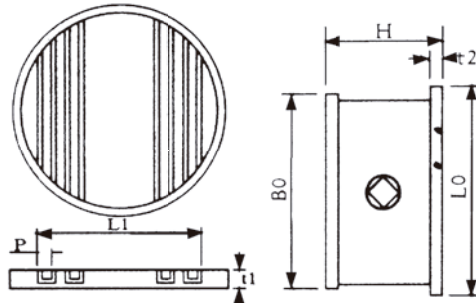

ORDER NO. VGD TYPE  
Magnetic field intensity:  
Higher than 650 gauss

## APPLICATION

Suitable for light cutting and grinding on lathe, grinder, EDM and the Rotary Table.

Unit:mm

ORDER NO.	FACE PLATE			BOTTOM PLATE		POLE PITCH P	HEIGHT H	WEIGHT KGS	CODE NO.
	B0	t1	L1	t2	L0				
VGD-06	150	21	101	18	200	9 (2+7)	78	9.8	2015-150
VGD-08	200		137		200			12.8	2015-151
VGD-10	250		191		250			20.2	2015-152
VGD-12	300		227		305			30.4	2015-153

# Fine Pole Round Type Magnetic Plate

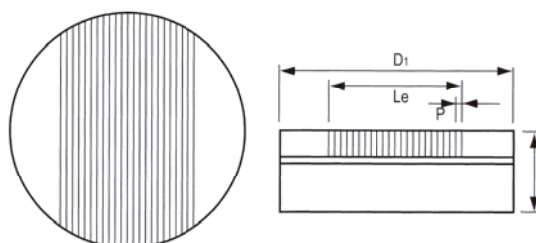
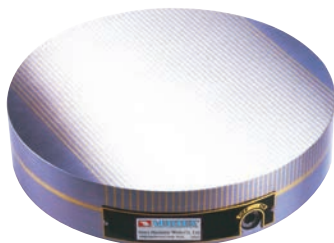

## APPLICATION

New type of thin chuck, in 50mm thickness, for grinding and electro-discharging works, for thin plate or small works, in wide range of applications, it features a wide effective magnetic area on the face plate (chucking face).

450 GAUSS

Unit:mm

ORDER NO.	DIAMETER	TOP PLATE		POLE PITCH P	HEIGHT H	WEIGHT KGS	CODE NO.
		D1	Le				
VGDW-6	160mm	160	115	2.5 (1+1.5)	50	8	2015-154
VDGW-8	200mm	200	155	2.5 (1+1.5)	50	13	2015-155
VGDW-10	250mm	250	205	2.5 (1+1.5)	50	21	2015-156
VGDW-12	300mm	300	255	2.5 (1+1.5)	50	33.5	2015-157