

HP-50A

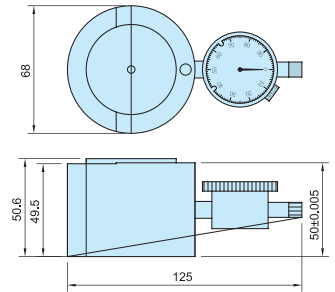

HP-50B



- Have the central measuring part of the zero setter presetter against a plain surface and aligned if with the outer reference surface. Turn the dial gauge for zero setting. Have the cutter touched against the z zero setter.
- Once the indicator position at zero, the distance between the tool tip to workpiece is 50mm,  $\pm 0.005$ , 100 mm,  $\pm 0.005$ .



HP-100AM

ORDER NO.	H	STYLE	WEIGHT (kg)	CODE NO.
HP-50A	50mm	STANDARD TYPE	1.1	3403-020
HP-50B			1.7	3403-021
HP-50AM		WITH MAGNETIC BASE	1.2	3403-022
HP-50BM			1.7	3403-023
HP-100A	100mm	STANDARD TYPE		3403-024
HP-100AM		WITH MAGNETIC BASE	1.77	3403-025

**NEW**

# Electronic Tool Length Setter

STAINLESS STEEL BASE WITH MAGNET

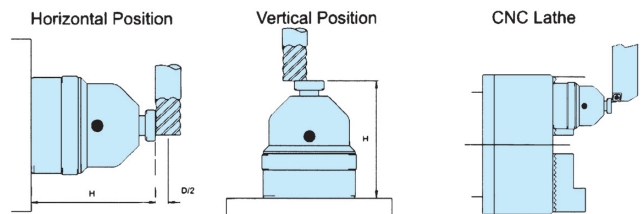
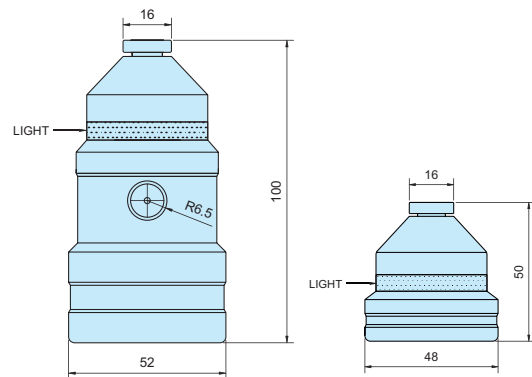

- **HIGH ACCURACY**
- **EASY OPERATION**

- Be sure to remove all chips and all from the sensor plate and the base of the HP-50E as well as from the workpiece and tool.
- To move the tool approaching the sensor plate slowly.
- When touching, the "LED" turns on immediately and "H" is just 50.00 mm.(or2")
- LED will not function if batteries are not set in correctly.
- Designed to be used on ferrous.

ORDER NO.	H	STYLE	WEIGHT (kg)	CODE NO.
HP-50EM	50mm	WITH MAGNETIC BASE	0.3	3403-032
HP-100EM	100mm		1.2	3403-033

## Stainless Steel Base With Magnet

TOOL PRE-SETTER FOR MACHINING CENTERS. CNC & STANDARD MILLING MACHINES AND CNC & STANDARD LATHES