

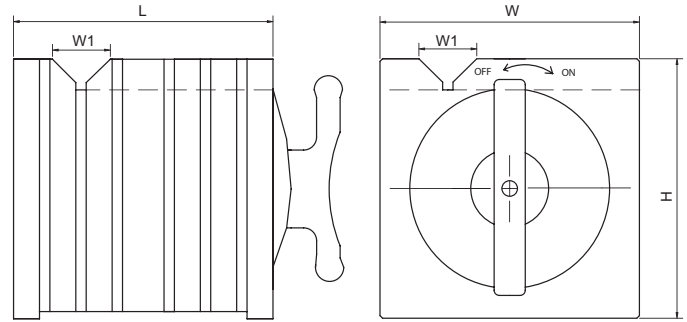

Magnetic Square Block

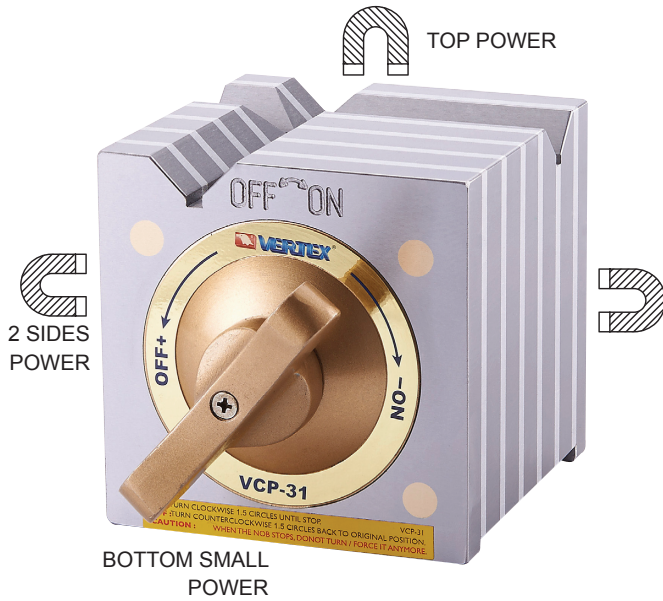

FOR MEASURING



MAGNETIC BLOCK

- The V-Blocks and Parallels transfer the magnetism from permanent magnetic chucks.
- The steel used in all V-Blocks and Parallels is selected for the highest magnetic transfer and is cast integrally with aluminum.
- For measuring

ORDER NO.	Mag. Power of V groove	Mag. Power of base	H	W	L	W1	Wt. kgs	CODE NO.
VCP-31	25kgs	50kgs	100 3.94"	100 3.94"	100 3.94"	26 1.02"	6.5	2015-530
VCP-32	50kgs	140kgs	150 5.91"	150 5.91"	150 5.91"	32 1.26"	20.4	2015-531



Magnetic Square Holder

NEW

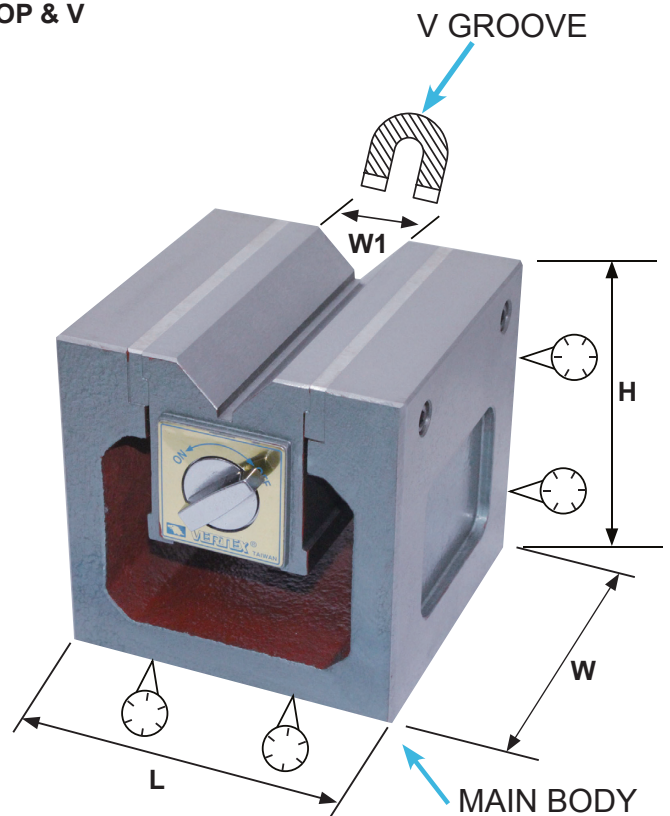
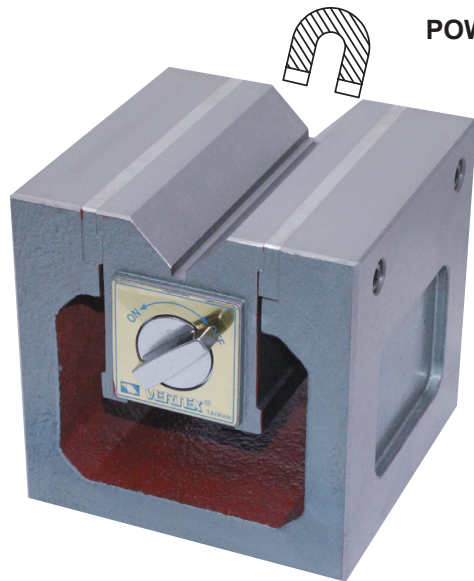

- Precision ground
- Base & V groove parallelism : 0.02 / 100 mm
- Magnetic power : V groove only
- MAIN BODY : CAST IRON
- Light duty, for measuring
- Easy movement
- Multi - type

ORDER NO.	Mag. Power of V groove	H	W	L	W1	Wt. kgs	CODE NO.
VCP-40	35kgs	125	125	125	38	8.54	2015-540